

DUST PROOF STRIKE

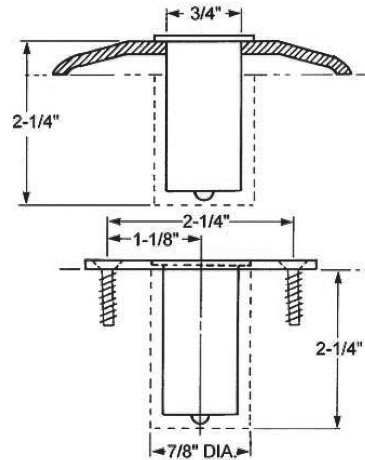

DPS280
Dust Proof Strike



SPECIFICATIONS

Material	Extruded Brass
Spring	Loaded 3/4" plunger
Installation	Both floor and threshold installation
Face plate	3" x 1-1/2"
Body diameter	15/16"
Over all depth	2-1/4"
Strike Screws	#12 x 1-1/2"
Anchors	Plastic
Test	UL fire rated for use up to 3 hours

FEATURES

Suitable for both floor and threshold installation, the INOX Spring-Loaded Strike boasts an extruded brass construction for maximum strength and reliability and includes strike screws and anchor.

The spring-loaded plunger returns to floor level when flushbolt is retracted.

CODE COMPLIANCE



ANSI - A156.16 - L24011, L24021
 Conforms to UL 10C and UBC 7-2
 ANSI A117.1 and ADA for Barrier-Free accessibility
 C-UBC-California Amended Uniform Builders Code
 NFPA 80 - National Fire Protection Association
 NFPA 101- National Fire Protection - Life Safety

Description

Dust Proof Strike (ANSI: L24011, L24021)

For additional finish options not listed, contact Sales Department for MOQ and lead times

Part Number

DPS280

Standard Finish

26D Satin Chrome