

**BOTTOM EDGE
OF DOOR**

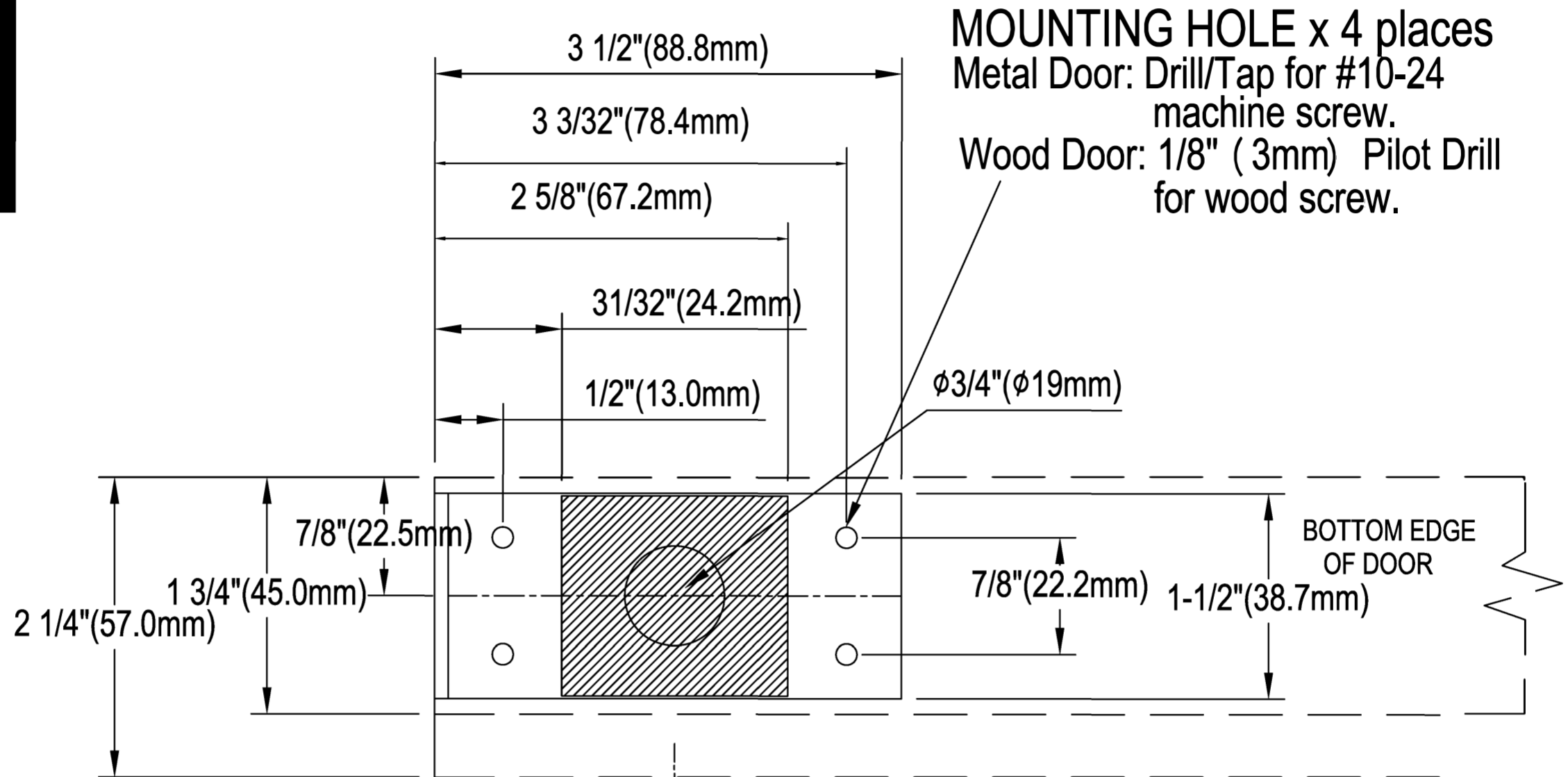

MOUNTING HOLES

Metal Door:

To weld two steel mounting plates (Y1, Y2) on bottom edge of door for mounting bottom latch assembly use.

Wood Door:

Cut out and bore the oblique line area on bottom edge of door for mounting bottom latch assembly use.

• PRIMARY DIMENSIONS SHOWN INCHES, DIMENSIONS IN () ARE MILLIMETERS.

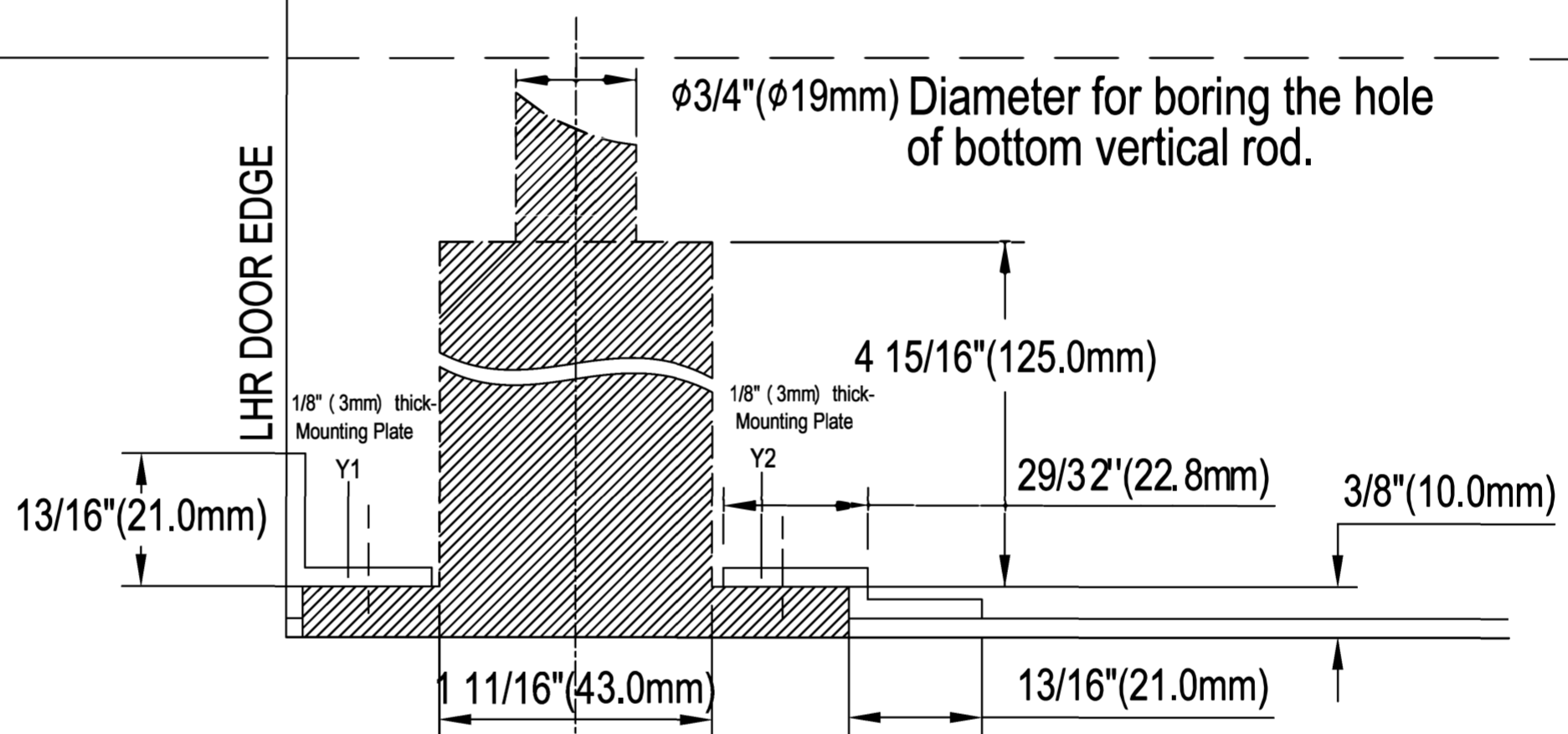

**FINISHED
FLOOR**

For RHR door use, invert this template.

