

# Manual Flushbolt for Wood Doors

FB196W

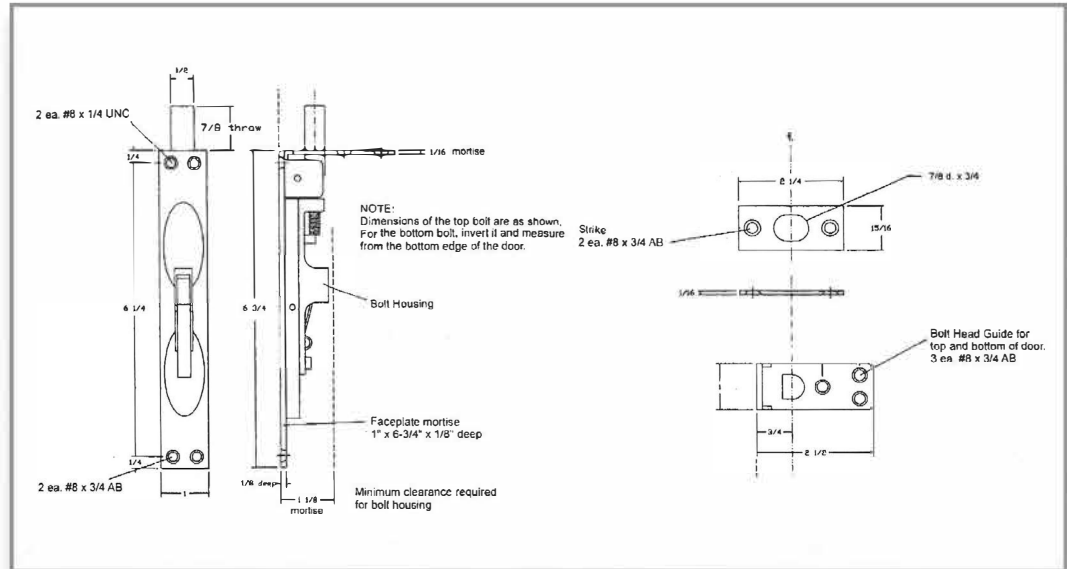

**FB196W**



## Features

- FB196W - Forged Brass - ANSI: L14251
- Non-Handed
- 3/4" Throw with 7/8" Vertical Adjustment
- Spring Loaded Lever to Project or Retract Bolt
- Forged Brass Construction
- Bolt Housing Screws #8 x 32 x 1/2" MS  
#8 x 1" SM
- Strike Screws #8 x 32 x 1/2" MS  
#8 x 1" SM
- Bolt Guide Screws #8 x 32 x 1/2" MS  
#8 x 1" SM
- Listed up to 1-1/2 hours on Wood and Composite Doors up to 8 feet.

## Finishes

- Stocking: US26D (626) Satin Chrome  
Special Order:
- . US3 (605) Bright Brass
  - . US4 (606) Satin Brass
  - . US10B (613) Oil Rubbed Bronze
  - . US26 (625) Bright Chrome

## Warranty

3 Year Warranty

## Specifications

Manual Flushbolts shall be by INOX® model number FB196W and made from forged brass. Flush bolts shall be provided with 1/2" diameter brass bolts and project 5/8" from the top or bottom edge of door with 7/8" vertical adjustment. Flush bolts shall have spring loaded lever to project or retract the bolts.

## Code Compliance



- FED.SPEC. - 1049
- ANSI A156.16 - L14261
- NFPA80 - National Fire Protection Association