

PD96 Components List

	Part Lists	10	40	50	53	60	70	80	90	92	95
A	X Series Trim	1EA	1EA	1EA	1EA	1EA	1EA	1EA	1EA	1EA	1EA
B	Cylinder & Keys	-	-	1EA	1EA	-	1EA	1EA	-	-	1EA
C	Thumbturn	-	-	1EA	1EA	1EA	-	-	-	-	-
D	Thumbturn & Coin Turn	-	1EA	-	-	-	-	-	-	-	-
E	Mortise Lock & Faceplate	1EA	1EA	1EA	1EA	1EA	1EA	1EA	1EA	1EA	1EA
F	Strike Plate w/ Dust Box	1EA	1EA	1EA	1EA	1EA	1EA	1EA	1EA	1EA	1EA

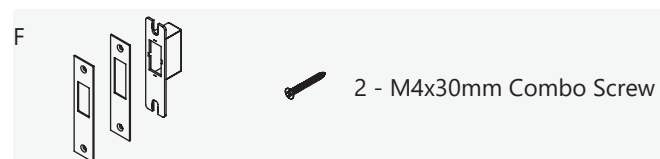
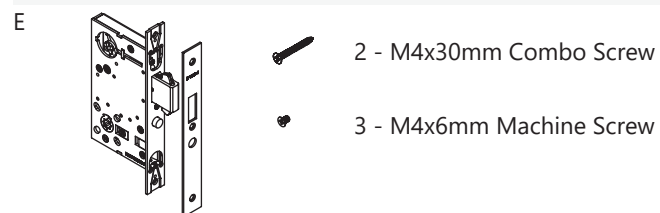
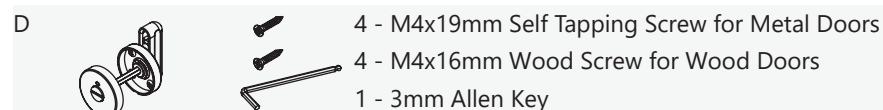
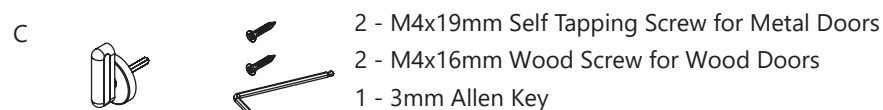
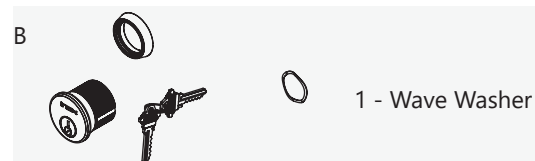
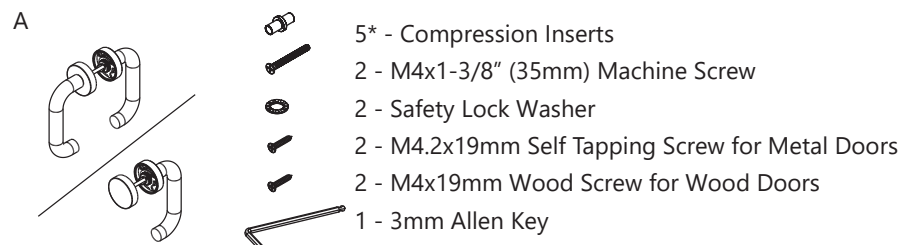

www.inoxproducts.com

* Extra fasteners provided for convenience

Installation Instructions

PD96 Self-Latching Mortise Lockset for Sliding Door with X Series Trim

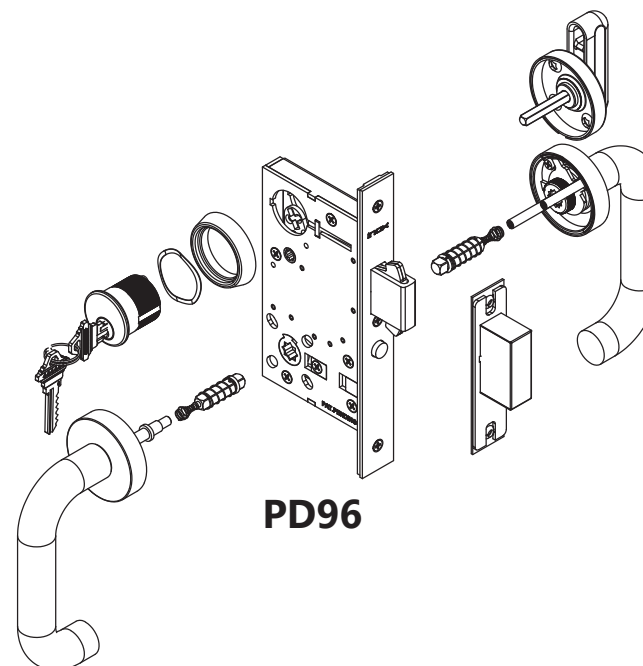

This product has been tested and certified for UL1784.

It is intended to be installed in accordance with the installation wiring diagram, mechanical assembly drawings provided with each product, the local authority having jurisdiction (AHJ) and the National Electric Code, NFPA 70. When installed in fail secure mode, the local authority shall be consulted with regard to the use of possible panic hardware to allow emergency exit from the secure area.

www.inoxproducts.com

PM-ISPD96
V20230809

Installation Instructions for Passage Function: PD9610 with X Series Trim

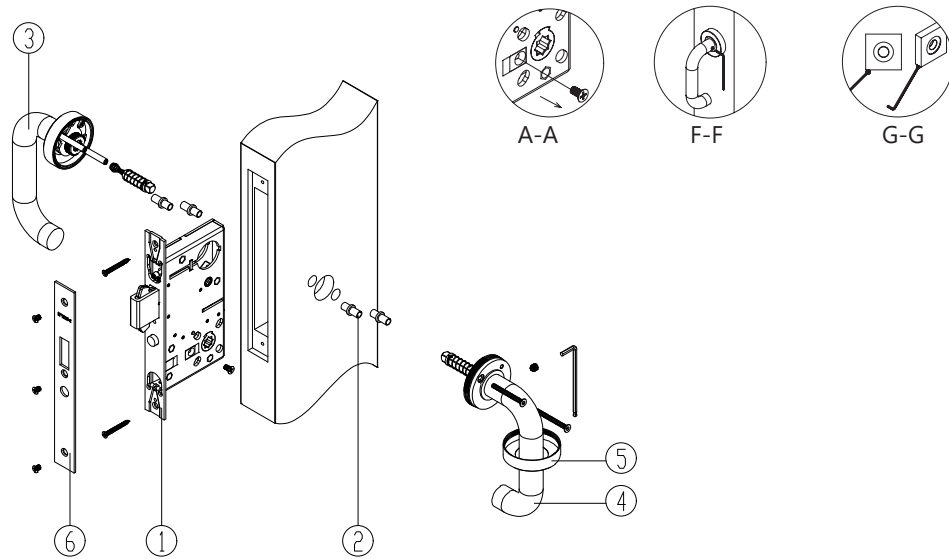

1. Install mortise lockcase in door prep. **NOTE:** Make sure handing screws from both sides of the lockcase have been removed. See section A-A.
2. Install the compression inserts on both sides.
3. Install outside X series trim. Do not tighten the set screws.
4. Install inside X series trim and tighten the M4x35mm screws.
5. Install the inside rose cover. XGT is threaded, XGS requires a set screw.
NOTE: After the lever is installed, fully tighten the set screws for both inside and outside trim. See Section F-F. **NOTE:** For XGS square rose, ensure that the rose is aligned prior to tightening the set screw. See section G-G.
6. Install armored faceplate with M4 screws.

Installation Instructions for Privacy Function: PD9640 with X Series Trim

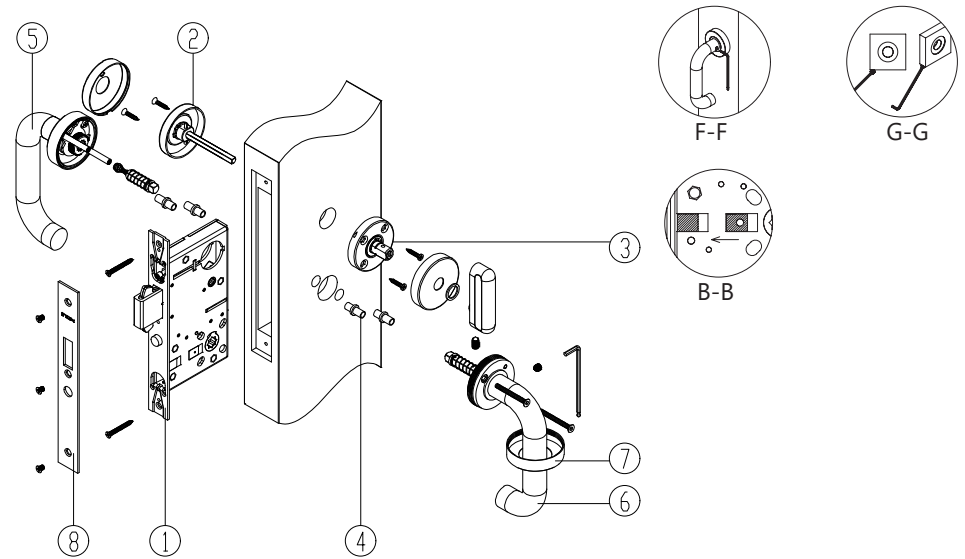

1. Install mortise lockcase in door prep. **NOTE:** Make sure the Entry locking block is justified toward the faceplate of the lock. See section B-B.
2. Install outside thumbturn release sub-rose and tighten screws.
3. Mount inside privacy thumbturn rose with M4 screws. Mount rose cover and clear washer before mounting thumbturn piece. Use Allen Key to tighten set screws. Mount the outside thumbturn release rose cover.
4. Install the compression inserts on both sides.
5. Install outside X series trim. Do not tighten the set screws.
6. Install inside X series trim and tighten the M4x35mm screws.
7. Install the inside rose cover. XGT is threaded, XGS requires a set screw.
NOTE: After the lever is installed, fully tighten the set screws for both inside and outside trim. See section F-F. **NOTE:** For XGS square rose, ensure that the rose is aligned prior to tightening the set screw. See section G-G.
8. Install armored faceplate with M4 screws.

Installation Instructions for Inner Entry Function: PD9650 with X Series Trim

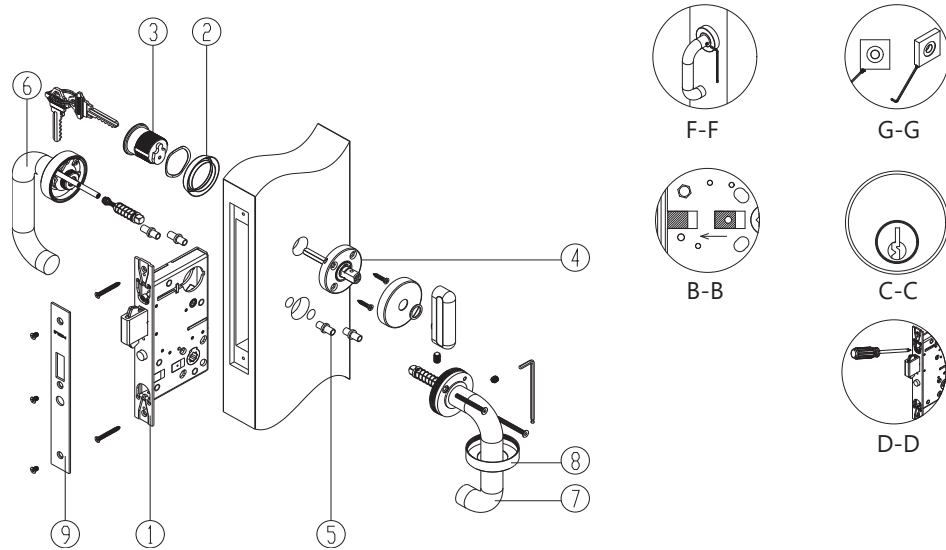

1. Install mortise lockcase in door prep. **NOTE:** DO NOT tighten the faceplate screws until the cylinder has been installed. **NOTE:** Make sure the Entry locking block is justified toward the faceplate of the lock. See section B-B.
 2. Screw on outside cylinder escutcheon ring with spacer.
 3. Install mortise cylinder. **NOTE:** Key slot on cylinder should be on lower center position. See section C-C. Using a screwdriver, tighten the M4 screws on the lockcase to position the cylinder into place. See section D-D.
 4. Mount inside privacy thumbturn rose with M4 screws. Mount rose cover and clear washer before mounting thumbturn piece. Use Allen Key to tighten set screws.
 5. Install the compression inserts on both sides.
 6. Install outside X series trim. Do not tighten the set screws.
 7. Install inside X series trim and tighten the M4x35mm screws.
 8. Install the inside rose cover. XGT is threaded, XGS requires a set screw.
- NOTE:** After the lever is installed, fully tighten the set screws for both inside and outside trim. See section F-F. **NOTE:** For XGS square rose, ensure that the rose is aligned prior to tightening the set screw. See section G-G.
9. Install armored faceplate with M4 screws.

Installation Instructions for Entrance Function: PD9653 with X Series Trim

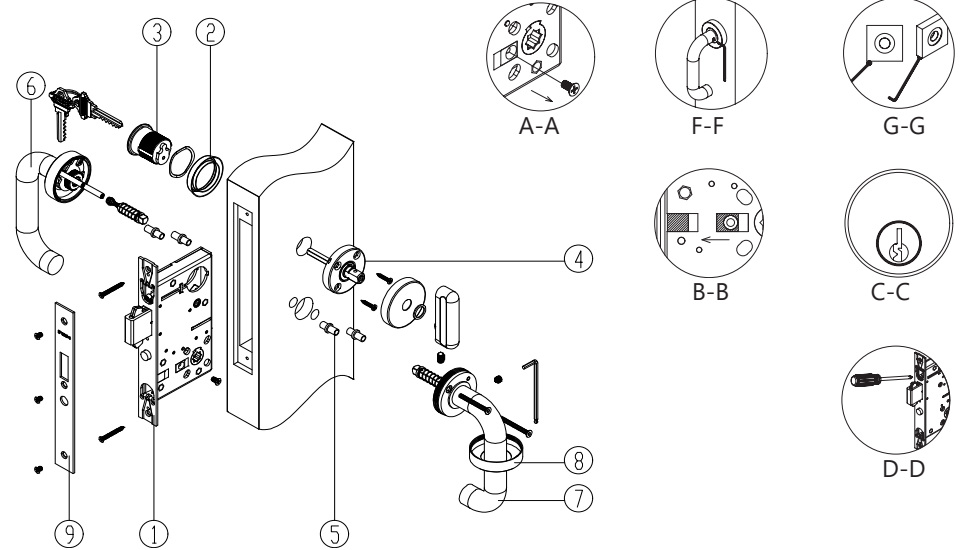

1. Install mortise lockcase in door prep. **NOTE:** DO NOT tighten the faceplate screws until the cylinder has been installed. Make sure the handing screws from the interior room side of the lockcase have been removed. See section A-A. **NOTE:** Make sure the Entry locking block is justified toward the faceplate of the lock. See section B-B.
 2. Screw on outside cylinder escutcheon ring with spacer.
 3. Install mortise cylinder. **NOTE:** Key slot on cylinder should be on lower center position. See section C-C. Using a screwdriver, tighten the M4 screws on the lockcase to position the cylinder into place. See section D-D.
 4. Mount inside privacy thumbturn rose with M4 screws. Mount rose cover and clear washer before mounting thumbturn piece. Use Allen Key to tighten set screws.
 5. Install the compression inserts on both sides.
 6. Install outside X series trim. Do not tighten the set screws.
 7. Install inside X series trim and tighten the M4x35mm screws.
 8. Install the inside rose cover. XGT is threaded, XGS requires a set screw.
- NOTE:** After the lever is installed, fully tighten the set screws for both inside and outside trim. See section F-F. **NOTE:** For XGS square rose, ensure that the rose is aligned prior to tightening the set screw. See section G-G.
9. Install armored faceplate with M4 screws.

Installation Instructions for Patio Function: PD9660 with X Series Trim

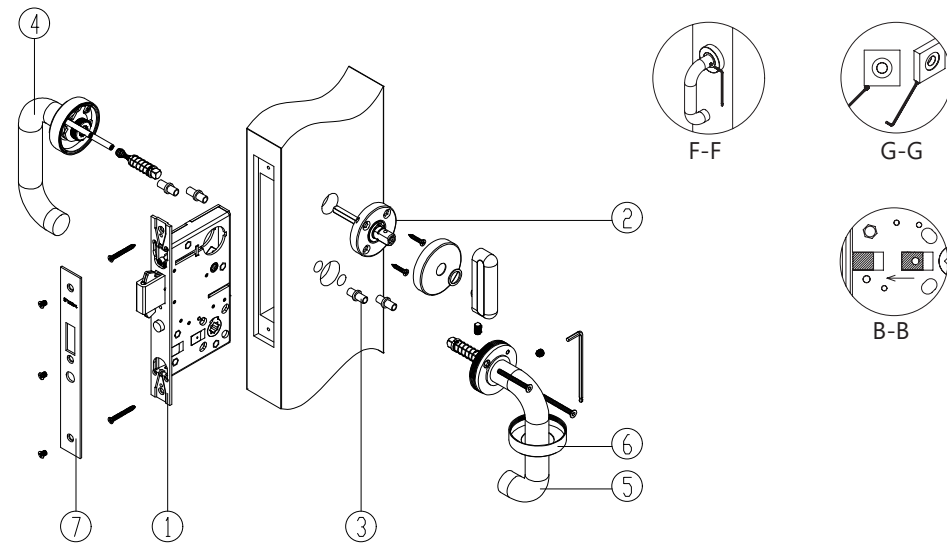

1. Install mortise lockcase in door prep. **NOTE:** Make sure the Entry locking block is justified toward the faceplate of the lock. See section B-B.
2. Mount inside privacy thumbturn rose with M4 screws. Mount rose cover and clear washer before mounting thumbturn piece. Use Allen Key to tighten set screws.
3. Install the compression inserts on both sides.
4. Install outside X series trim. Do not tighten the set screws.
5. Install inside X series trim and tighten the M4x35mm screws.
6. Install the inside rose cover. XGT is threaded, XGS requires a set screw.
NOTE: After the lever is installed, fully tighten the set screws for both inside and outside trim. See section F-F. **NOTE:** For XGS square rose, ensure that the rose is aligned prior to tightening the set screw. See section G-G.
7. Install armored faceplate with M4 screws.

Installation Instructions for Classroom Function: PD9670 with X Series Trim

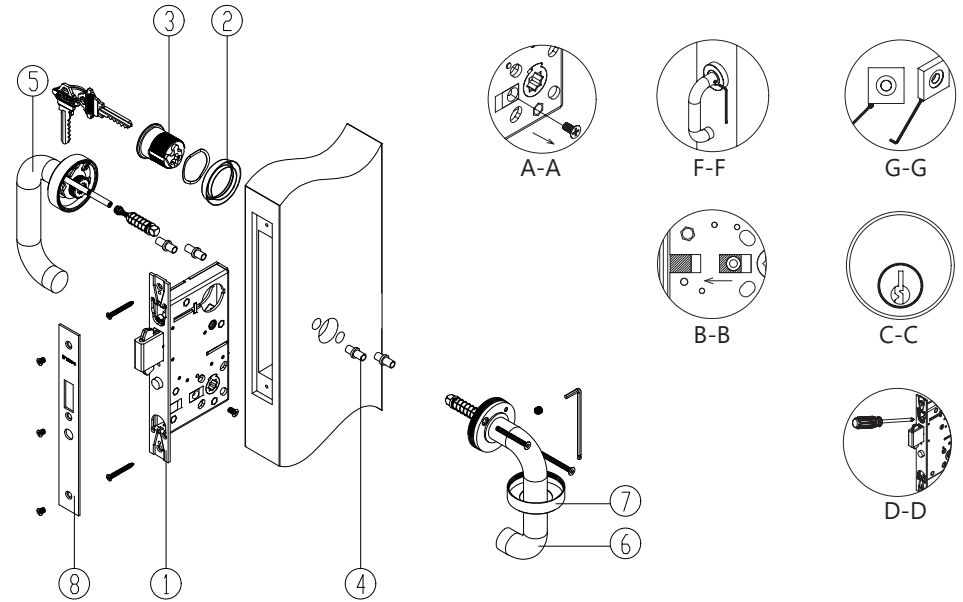

1. Install mortise lockcase in door prep. **NOTE:** DO NOT tighten the faceplate screws until the cylinder has been installed. Make sure handing screws from the interior room side of the lockcase have been removed. See section A-A.
NOTE: Make sure the Entry locking block is justified toward the faceplate of the lock. See section B-B.
2. Screw on outside cylinder escutcheon ring with spacer.
3. Install mortise cylinder. **NOTE:** Key slot on cylinder should be on lower center position. See section C-C. Using a screwdriver, tighten the M4 screws on the lockcase to position the cylinder into place. See section D-D.
4. Install the compression inserts on both sides.
5. Install outside X series trim. Do not tighten the set screws.
6. Install inside X series trim and tighten the M4x35mm screws.
7. Install the inside rose cover. XGT is threaded, XGS requires a set screw.
NOTE: After the lever is installed, fully tighten the set screws for both inside and outside trim. See section F-F. **NOTE:** For XGS square rose, ensure that the rose is aligned prior to tightening the set screw. See section G-G.
8. Install armored faceplate with M4 screws.

Installation Instructions for Storeroom Function: PD9680 with X Series Trim

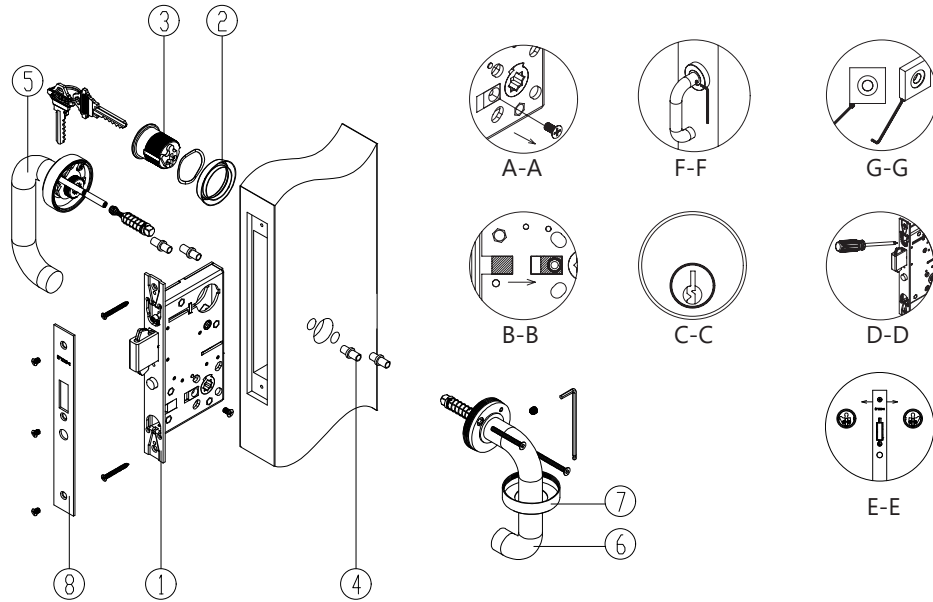

1. Install mortise lockcase in door prep. **NOTE:** DO NOT tighten the faceplate screws until the cylinder has been installed. Make sure handing screws from the interior room side of the lockcase have been removed. See section A-A. **NOTE:** Make sure the Entry locking block is justified away from the faceplate of the lock. See section B-B.
2. Screw on outside cylinder escutcheon ring with spacer.
3. Install mortise cylinder. **NOTE:** This function requires a special cylinder cam. See section E-E. **NOTE:** Key slot on cylinder should be on lower center position. See section C-C. Using a screwdriver, tighten the M4 screws on the lockcase to position the cylinder into place. See section D-D.
4. Install the compression inserts on both sides.
5. Install outside X series trim. Do not tighten the set screws.
6. Install inside X series trim and tighten the M4x35mm screws.
7. Install the inside rose cover. XGT is threaded, XGS requires a set screw. **NOTE:** After the lever is installed, fully tighten the set screws for both inside and outside trim. See section F-F. **NOTE:** For XGS square rose, ensure that the rose is aligned prior to tightening the set screw. See section G-G.
8. Install armored faceplate with M4 screws.

Installation Instructions for Exit Function: PD9690 with X Series Trim

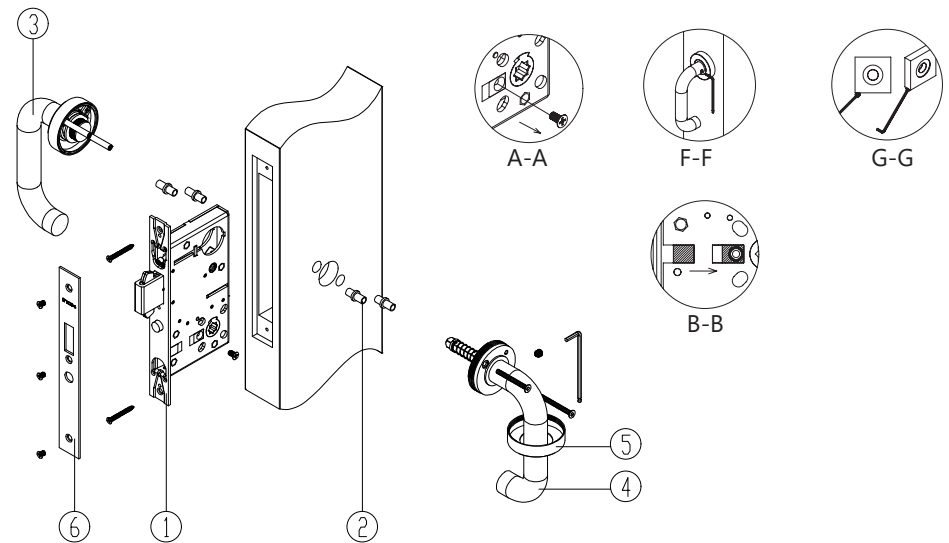

1. Install mortise lockcase in door prep. **NOTE:** Make sure handing screws from the interior room side of the lockcase have been removed. See section A-A. **NOTE:** Make sure the Entry locking block is justified away from the faceplate of the lock. See section B-B.
2. Install the compression inserts on both sides.
3. Install outside X series trim. Do not tighten the set screws.
4. Install inside X series trim and tighten the M4x35mm screws.
5. Install the inside rose cover. XGT is threaded, XGS requires a set screw. **NOTE:** After the lever is installed, fully tighten the set screws for both inside and outside trim. See section F-F. **NOTE:** For XGS square rose, ensure that the rose is aligned prior to tightening the set screw. See section G-G.
6. Install armored faceplate with M4 screws.

Installation Instructions for Communicating Function: PD9692 with X Series Trim

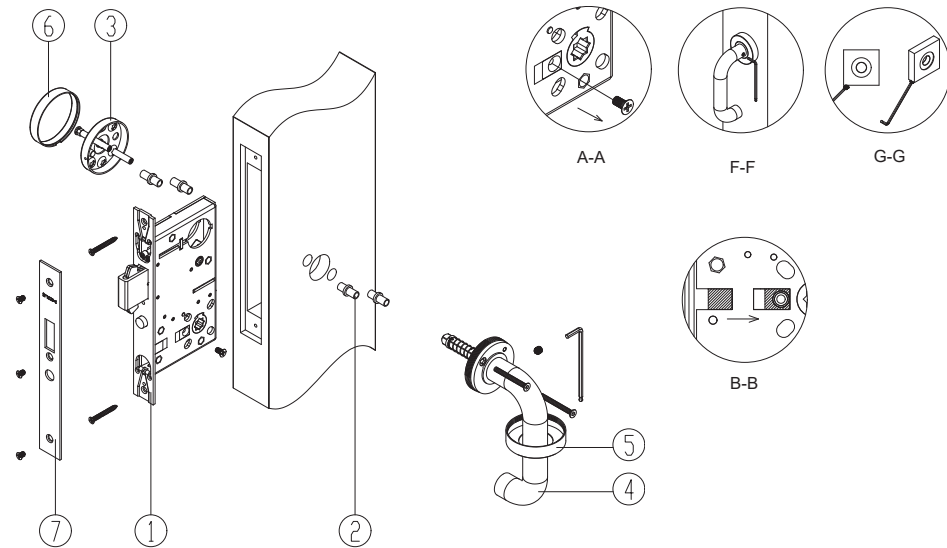

1. Install mortise lockcase in door prep. **NOTE:** Make sure handing screws from the lever side of the lockcase have been removed. See section A-A.
NOTE: Make sure the Entry locking block is justified away from the faceplate of the lock. See section B-B.
2. Install the compression inserts on both sides.
3. Install the outside blank sub-rose.
4. Install inside X series trim and tighten the M4x35mm screws.
5. Install the inside rose cover. XGT is threaded, XGS requires a set screw. **NOTE:** After the lever is installed, fully tighten the set screw for the lever trim. See section F-F. **NOTE:** For XGS square rose, ensure that the rose is aligned prior to tightening the set screw. See section G-G.
6. Install the outside blank rose cover.
7. Install armored faceplate with M4 screws.

Installation Instructions for Security Communicating: PD9695 with X Series Trim

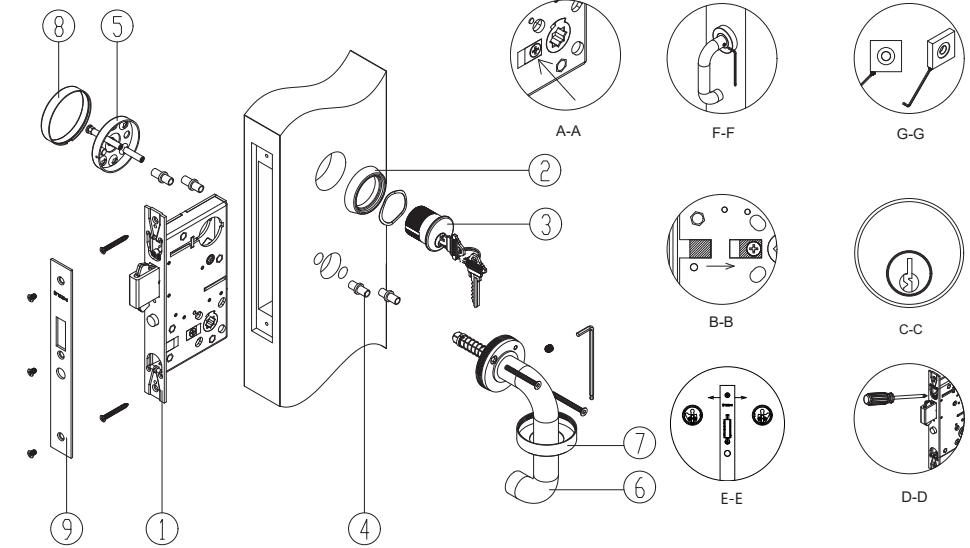

1. Install mortise lockcase in door prep. **NOTE:** Do not remove the handing screws from either side. See section A-A. **NOTE:** DO NOT tighten the faceplate screws until the cylinder has been installed. **NOTE:** Make sure the Entry locking block is justified away from the faceplate of the lock. See section B-B.
2. Screw on outside cylinder escutcheon ring with spacer.
3. Install mortise cylinder. **NOTE:** This function requires a special cylinder cam. See section E-E. **NOTE:** Key slot on cylinder should be on lower center position. See section C-C. Using a screwdriver, tighten the M4 screws on the lockcase to position the cylinder into place. See section D-D.
4. Install the compression inserts on both sides.
5. Install the outside blank sub-rose.
6. Install inside X series trim and tighten the M4x35mm screws.
7. Install the inside rose cover. XGT is threaded, XGS requires a set screw. **NOTE:** After the lever is installed, fully tighten the set screw for the lever trim. See section F-F. **NOTE:** For XGS square rose, ensure that the rose is aligned prior to tightening the set screw. See section G-G.
8. Install the outside blank rose cover.
9. Install armored faceplate with M4 screws.